

# FISHING GEAR AND METHODS USED TO HARVEST TROPICAL TUNAS IN THE EEZ OF PAKISTAN

By: S. HUSSAIN & RIZWAN AHMED

## INTRODUCTION

Received: 16 October, 2011  
IOTC-2011-WPTT13-14

- ▶ The principal fishing methods / gear used in the Marine waters of Pakistan are mainly of four (04) types namely Trawling, Gillnetting, Long-lining (for demersal fish) and fishing of small pelagics with surrounding nets (purse-seine type, but without purse lines and rings). The crafts used under all of these fishing activities, are wooden-hull; trawlers, gillnetters and long-liners are fitted with in-board marine engines, whereas the Hora boats, that are using surrounding nets, are equipped with out-board motors.
- ▶ Trawlers, Long-liners and Hora boats vary in size from 07m to 18m in overall length; whereas the gillnetters are from 12m to 23m in overall length and are used to catch variety of demersal and pelagic fish species including large pelagics.

## ▶ Fishing method(s) used to Harvest Tunas

Gillnetting is the only fishing method used to harvest tropical tunas in deeper waters. The National Pak. Flag fleet of gillnetters engaged in catching tuna and tuna like species is comprised of about 200 boats (in actual operation). Particulars of a typical gillnetter are as under:

Length overall	:	22 m
Keel Length	:	15 m
Breadth	:	07 m
Depth	:	04 m
Gross Tonnage	:	144
Net Tonnage	:	97
Engine H.P	:	400
Engine R.P.M.	:	1900
Engine Cylinder	:	6

These boats are mainly based at Karachi and Korangi area on Sindh coast and Gawadar and Sonmiani on Balochistan coast. Below is a picture of gillnetter namely Safina-E-Abdul Wahid (Reg:16520-B) which illustrates layout of its deck.

AHID

سید عبد الواحد 16520.B





The gillnet used by these gillnetters is known as “Ruch”, which is made up of polyamide (Nylon) continuous multi filament netting. One strip of the net is 100m in assembled length having the following technical parameters.

Length of Head Rope	:	100 m
Material of Head Rope	:	Polyester
Diameter of Head Rope	:	14 mm
Length of Foot Rope	:	100 m
Material of Foot Rope	:	Polyester
Diameter of Foot Rope	:	16 mm
Netting Material	:	Polyamide-210/24
Mesh Size	:	150 mm (stretched)
Number of Meshes (in length)	:	1334
Number of Meshes (in depth)	:	120
Hanging Ratio (E)	:	0.5
Floatation	:	24PVC (each dia. =115mm x L=130 mm)
Sinkers	:	05 stones (3Kgs each)

# THE TECHNICAL DRAWING OF TYPICAL DRIFT GILLNET

VESSEL  
Loa 22m  
GT 144

100m PES Ø 14mm

E=0.5

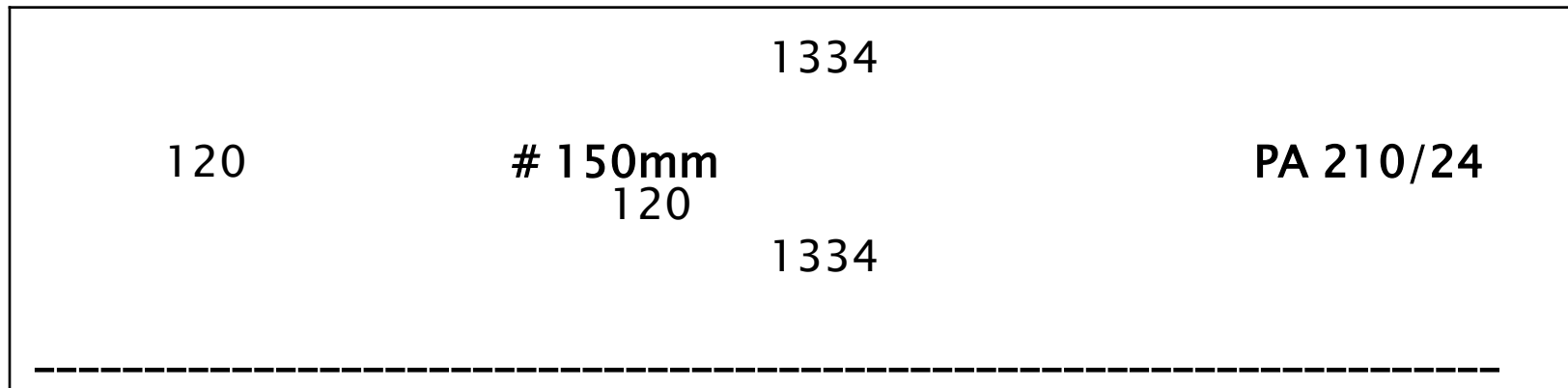

100m PES Ø 16mm

E=0.5

# ASSEMBLING OF TYPICAL DRIFT GILL NET

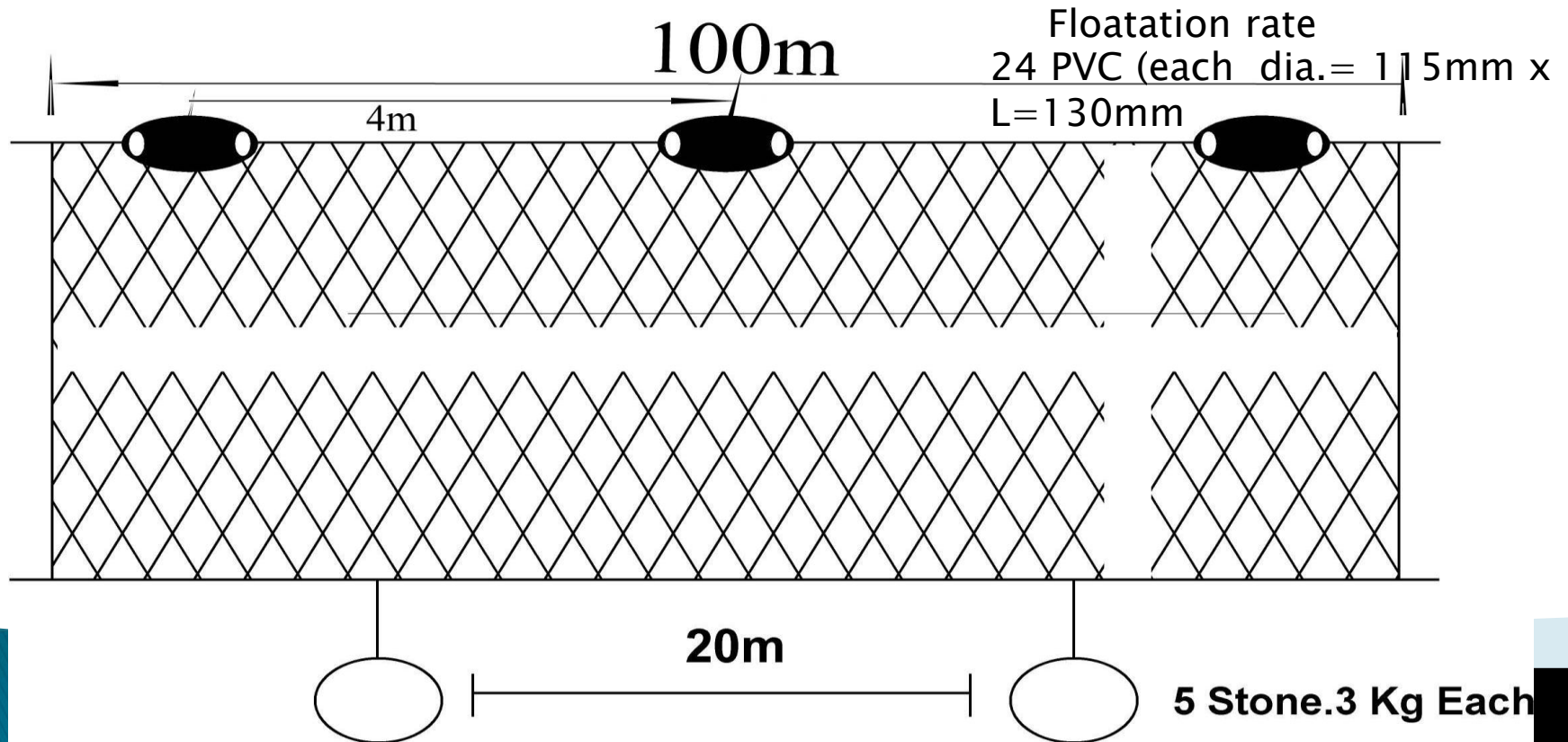

An average number of 25 strips of gillnet are used in one set, which vary from boat to boat and fishing ground to fishing ground. A marking Flag is used after 03 strips; whereas a marking buoy is used after 10 strips of gillnet.

Usually the fishermen set the gillnet after sun set and haul in the early morning. The catch is preserved in ice. The main targeted species are:

YELLOW FIN TUNA (*Thunnus albacares*), SKIPJACK TUNA (*Kaetsuwonus pelamis*), KAWA KAWA (*Euthynnus affinis*), LONG TAIL TUNA (*Thunnus tonggol*), FRIGATE TUNA (*Auxis thazard*), STRIPED BONETO (*Sarda orientalis*).



# FISHERMEN PREPARING BEFORE LEAVING FOR THE FISHING GROUND



## Conclusion:-

In the recent years, the attitude of fishermen has changed in three ways:

- (a) Conversion from dry salted practices to preservation of catch with ice because of fetching better prices in the market as compared to salted dried fish;
  - (b) Reduction in number of fishing days to bring quality product back to the port; and
  - (c) Reduction in size of the net to reduce the hauling time in order to avoid retention of fish catch in water for longer period.
- 